

Auxiliary power supply German technology for trams in China



- Auxiliary power units for supplying AC loads in a rail vehicle with integrated battery charger
- German technology with production and full customer service in China
- Full range of products to fit the main tramway platforms Flexity, Combino and Citadis
- Light weight and compact design thanks to medium-frequency electrical isolation
- Electrical design adapted to fit with Chinese tramway needs
- Easy maintenance thanks to modular design
- Low noise emission thanks to speed control fan
- Communication with the vehicle via IP, CAN Open or MVB
- Parallel connection of AC or DC Outputs possible
- Dead battery start functionality
- Variable AC output voltages and frequencies

References: About 10,000 units for trams running all around the globe



POWERTECH

MARKET LEADER IN CHINA

COMBINO

Place of operation	Wuhan, Guangzhou
Quantity	139 units
Delivery	since 2013
Weight	117 kg
Dimensions	953 x 679 x 545 mm

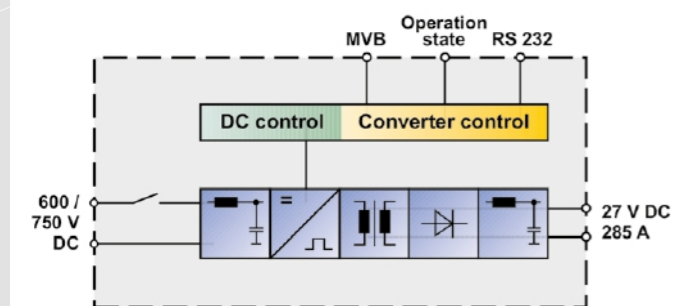

FLEXITY

Place of operation	Suzhou, Nanjing
Quantity	66 units
Delivery	since 2014
Weight	310 kg
Dimensions	1600 x 750 x 450 mm

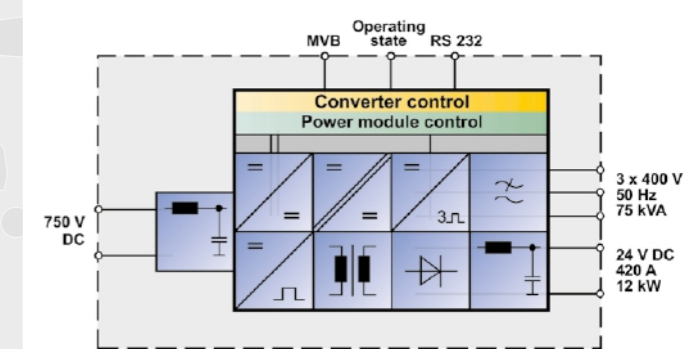

KNORR-BREMSE POWERTECH IN CHINA

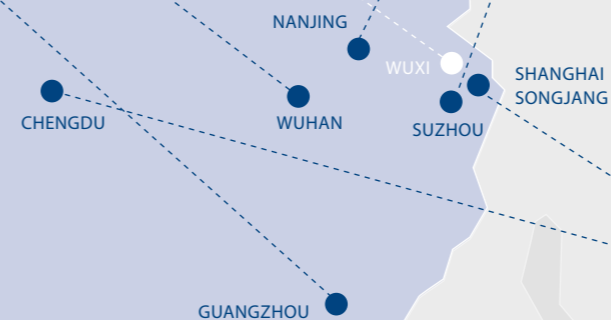

THE KNORR-BREMSE POWERTECH BRAND stands for electrical power supply systems for rail vehicles and industrial applications, manufactured to proven Knorr-Bremse quality standards. PowerTech was formed through the combination of two medium-sized companies that are leading specialists in auxiliary power converters:

PCS Power Converter Solutions GmbH in Berlin and Transtechnik GmbH & Co. KG in Holzkirchen. Both companies were acquired by Knorr-Bremse in January 2014 and changed their names to Knorr-Bremse Powertech GmbH, Berlin and Knorr-Bremse Powertech GmbH & Co. KG, Holzkirchen in 2016. All over the world our solutions contribute to greater mobility and a more secure energy supply in the 21st century. Together we develop solutions that set new standards for power converter technology and thus open up new opportunities for our customers.

POWERTECH IN BRIEF

- Part of the Knorr-Bremse Group since 2014
- More than 500 employees
- 4 sites on three continents
- Turnover in three-digit millions
- More than 100 years' experience in rail technology
- More than 60,000 power converters for rail vehicles and industry
- Some 60,000 electrical equipments for passenger rail cars
- Reference projects on all continents

POWERTECH CHINA IN BRIEF

- Full owned subsidiary of Knorr-Bremse PowerTech in China
- Sales and project management responsibility, local customer support and service.
- Experienced team located in Wuxi
- Manufacturing in China with local partner or in own facilities

CITADIS

Place of operation	Shanghai Songjiang, Chengdu
Quantity	48 units
Delivery	since 2016
Weight	494 kg
Dimensions	1584 x 1400 x 525 mm

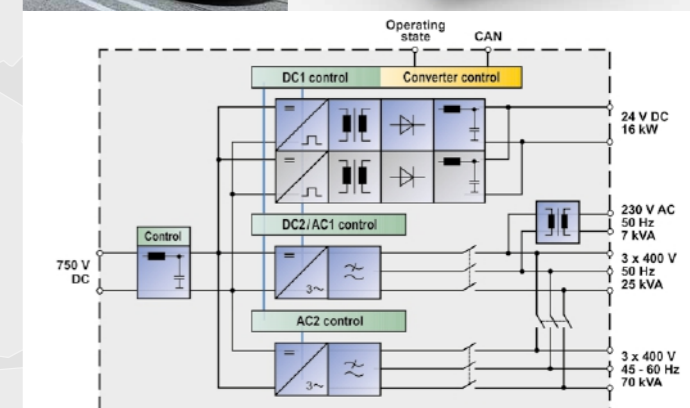

Knorr-Bremse Powertech GmbH

Am Borsigturm 100
13507 Berlin, Germany
Tel.: +49 30 297725 0
info.berlin@kb-powertech.com

Knorr-Bremse Powertech GmbH & Co. KG

Ohmstraße 1
83607 Holzkirchen, Germany
Tel.: +49 8024 990 0
info.holzkirchen@kb-powertech.com

Knorr-Bremse Powertech Corp. USA

300 International Drive, Suite 2
Mount Olive, New Jersey 07828, USA
Tel.: +1 973 527 6060
info.usa@kb-powertech.com

Knorr-Bremse Powertech China

Building 4, Jingxi Industry Park
2 Jingui Road, Hudai Town, Binhu District
214161 Wuxi, Jiangsu Province, PR China
Tel.: +86 510 6888 0513
info.china@kb-powertech.com

sales@kb-powertech.com
WWW.KB-POWERTECH.COM
WWW.KNORR-BREMSE.COM



Knorr-Bremse Group

This publication may be subject to alteration without prior notice. A printed copy of this document may not be the latest revision. Please contact your local Knorr-Bremse representative or check our website www.knorr-bremse.com for the latest update. The figurative mark „K“ and the trademarks KNORR and KNORR-BREMSE are registered in the name of Knorr-Bremse AG. Copyright 2016 © Knorr-Bremse AG. All rights reserved. Including industrial property rights applications. Knorr-Bremse AG retains any power of disposal, such as for copying and transferring.